

4

3

2

1

THIS DRAWING IS UNPUBLISHED. RELEASED FOR PUBLICATION  
 © COPYRIGHT - By - ALL RIGHTS RESERVED.

LOC	DIST	REVISIONS			
P	LTR	DESCRIPTION	DATE	DWN	APVD
AF	50	G	REVISED PER ECR-12-013459	29NOV2012	KH PD

- 1 CONTINUOUS STRIP ON REELS.
- 2 MATING TAB THK IS .020±.001
- 3 WIRE SIZE IS #20-#16 AWG
- 4 INSULATION RANGE IS .120-.140 DIA
- △5 SPECIAL PACKAGING
- △6 PRELIMINARY - NOT FOR PRODUCTION

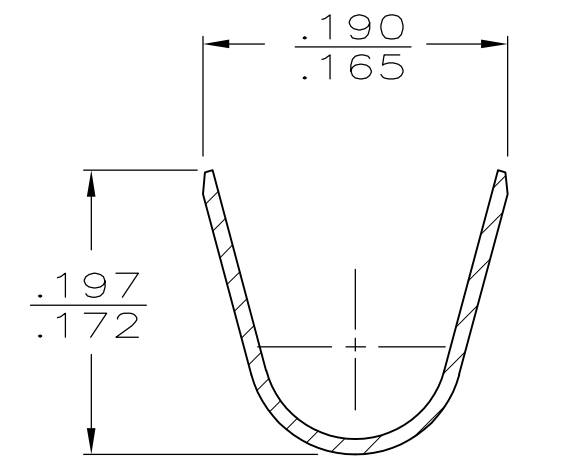
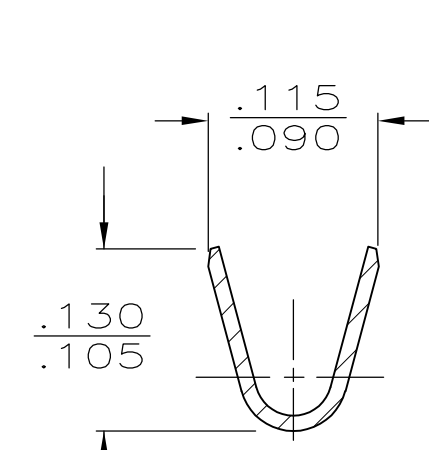
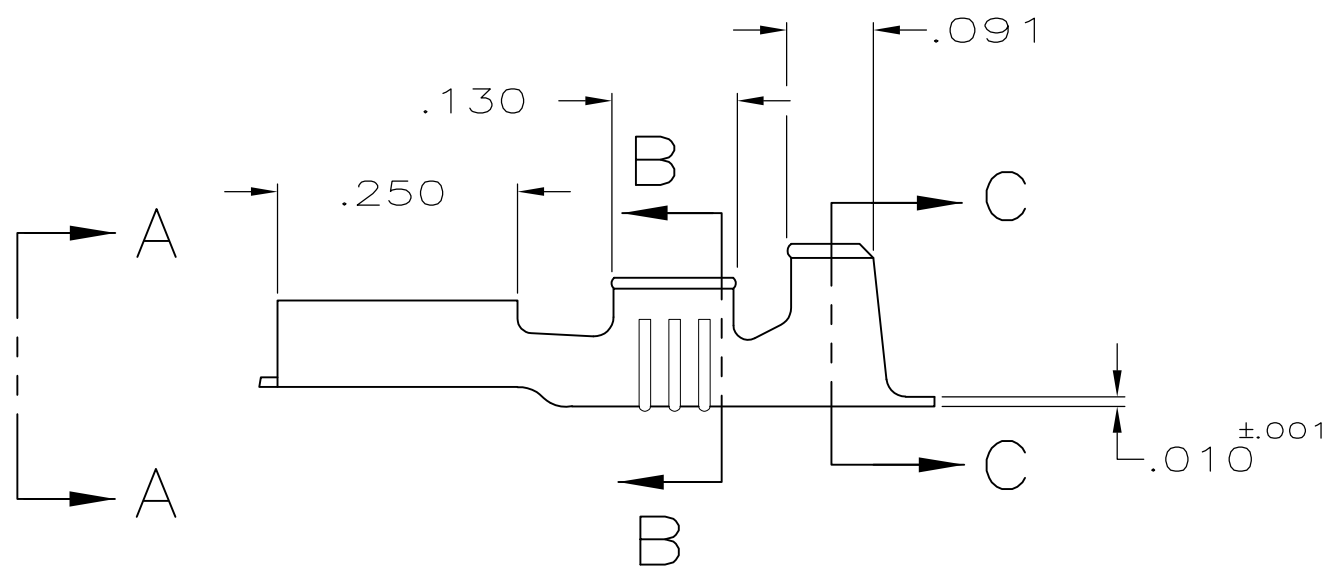
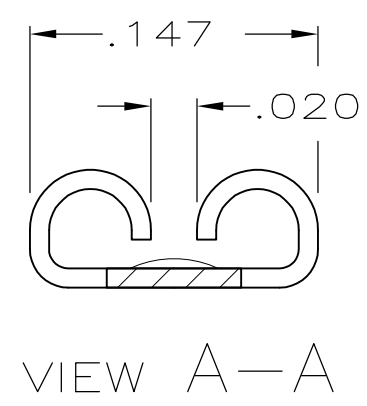
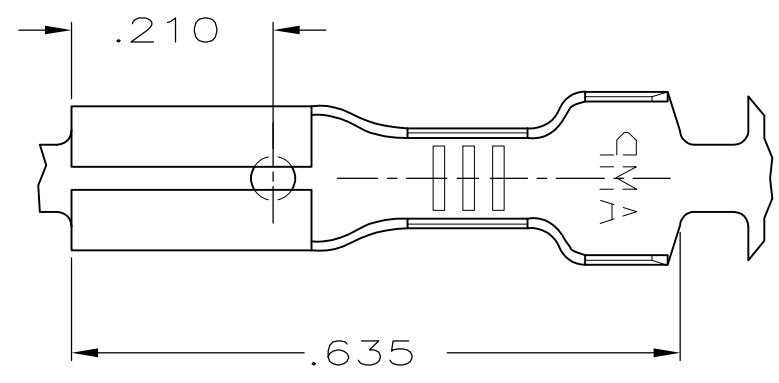

SECTION B-B

SECTION C-C

△5	PRE-TIN	△6	61400-3
	PRE-TIN		61400-1
	FINISH		PART NO

THIS DRAWING IS A CONTROLLED DOCUMENT.		DWN	JR RUTH	2/6/87	<b>STE</b> TE Connectivity		
DIMENSIONS: INCHES		CHK	R KUZO	2/17/87			
TOLERANCES UNLESS OTHERWISE SPECIFIED:		APVD	C MEYERS	2/16/87	NAME		
0 PLC ± -		PRODUCT SPEC		RECEPTACLE, FASTON, .110 SERIES			
1 PLC ± -		APPLICATION SPEC		SIZE	CAGE CODE	DRAWING NO	RESTRICTED TO
2 PLC ± -		MATERIAL		A300779		C-61400	-
3 PLC ± .015		FINISH		CUSTOMER DRAWING			SCALE
4 PLC ± -		SEE TABLE		5:1			SHEET
ANGLES ± -				1 OF 1			REV
				G			